



# ELECTRIC GRIDDLES

## MODELS :

**CPG24**

**CPG36**

**CPG48**

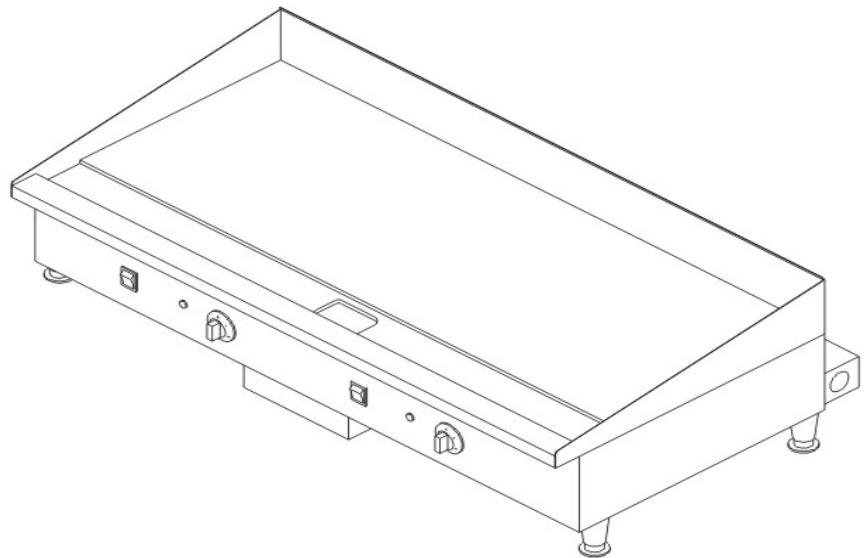

Commercial Pro  
International 5034-A  
Thoroughbred Lane  
Brentwood, TN 37027



**Congratulations on your purchase on your Commercial Pro International product. Provide in this manual are necessary details to ensure you operate this products efficiently, effectively and in a safe manner whilst maintaining the best possible performance. Please take time to carefully read through this manual**

## **PRODUCT CONTENTS**

CPI ensures that all of its products are supplied fully functional and free of damage at time of packaging. Your Griddle Includes:

- Griddle (nominated model)
- Feet x 4
- Grease Tray
- Manual

Inspect the contents of the package immediately on arrival. Should you find any damages as a result of freight, please contact your CPI dealer immediately. Save the box and all packaging materials. No Claims will be accepted after 3 days of receipt.

## **SPECIFICATION**

<b>Model</b>	<b>Dimension</b>	<b>Weight(kg)</b>	<b>Coverage</b>	<b>Plate</b>
CPG24	24.6"X17"X11.3"	28.8kg	23.8"X13"	Flat
CPG36	36"X19.3"X11.3"	40.3kg	35.8"X13"	Flat
CPG48	48"X19.3"X11.3"	60.7kg	47.8"X13"	Flat

## **ELECTRICAL SPECIFICATIONS**

<b>Model</b>	<b>Volts(V)</b>	<b>Watts(KW)</b>	<b>Amps(A)</b>	<b>Plug</b>
CPG24	208-240	2.7	13	6-20P/None
		3.6	15	
CPG36	208-240	4.05	19.5	None
		5.4	22.5	
CPG48	208-240	5.4	26	None
		7.2	30	

The Griddles are set up for hard wire installations. Please refer to electrical specifications and circuit diagrams. A qualified technician should be used for connection.

## COMPLIANCE

Commercial Pro International Products have undergone regulatory standard and testing procedures and as testimony to this carry the following marks and symbols:



## CAUTION

### IMPORTANT SAFEGUARDS & SAFETY INSTRUCTIONS

When using electrical food equipment, basic safety precautions should always be followed, including the following

- Read the instructions carefully before operating this equipment.
- Do not touch hot surfaces. Use handles or knobs.
- To protect against risk of electrical shock, do not put in water or other liquid.
- Close supervision is necessary when any appliance is used by or near children.
- Unplug from power outlet when not in use, before putting on or taking off parts, and before cleaning.
- Do not operate any equipment with a damaged cord or plug or after the appliance malfunctions or is dropped or damaged in any manner. Call for service.
- The use of attachments not recommended or sold by the manufacturer may cause fire, electrical shock or injury.
- Do not use outdoors.
- Do not let power cord or the extension cord hang over edge of table or counter or touch hot surfaces.
- Do not place on or near a hot gas or electric burner, or in a heated oven.
- Do not use this equipment for any use other than the use intended by the manufacturer.
- Do not yank on any cord to disconnect.
- Never plug equipment in where water floods the area.
- Place the appliance on a firm stable surface.
- The CPI Griddle does not contain **any** user-serviceable parts. CPI dealers or recommended qualified technicians should carry out repairs if necessary. Do not remove any components or service panels on this product.
- CPI takes every care to ensure that all products are safe. Steel cutting procedures used to manufacture these items results in sharp edges. These sharp edges are removed to the best of our ability however we insist the operator takes care when in contact with this piece of equipment.
- During operation the Griddle reaches high temperatures in the oil pan, in turn heating the stainless steel surfaces. Take extreme care when operating.
- Switch off power to and disconnect from the mains whilst cleaning.
- Allow the Griddle to cool down after use before dismantling for cleaning; the unit will be too hot to handle immediately after use.
- The Commercial Pro Electric Griddle is equipped for the voltage indicated on the nameplate mounted on the rear of the unit. This griddle is designed for use on alternating current (AC) only.

## **INSTALLATION**

**NOTICE:** Local codes regarding installation vary greatly by area. The National Fire Protection Association, Inc, states in it's NFPA 96 latest edition (see below) that local codes are "authority having jurisdiction" when it comes to requirements for installation of equipment. Therefore, installations should comply with all local codes.

Once you Griddle has been removed from the packaging, be certain that all protective plastics and residues are removed from all surfaces.

For Hardwiring, remove the junction box cover on the rear of griddle to expose the wire connections. Use one of the holes furnished for attaching the conduit with proper size clamp. All wires must be spliced or joined as to be electrically and mechanically secure and covered with insulation equal to that of the wire. Loose or improper connections may result in arcing, which in turn can cause a fire.

The installation of the Electric Griddle must conform to the NATIONAL ELECTRIC CODE AND ALL LOCAL ELECTRIC CODES AND ORDINANCES AND ALL THE LOCAL ELECTRICAL COMPANY RULES AND REGULATIONS. Additionally we recommend that the griddle is allowed a 4" spacing surrounding the unit in order to provide adequate ventilation.

For your protection we recommend that a qualified electrician install this griddle. They should be familiar with electrical installations and all electrical codes.

Proper connections and power supply are essential for efficient performance.

The external wiring should be in conduit or an approved type of flexible cable suitable for operation at temperature indicated at the conduit hole, and a proper size to carry the load.

The supply circuit should be properly fused and equipped with a means of disconnecting, as required by the local electrical code.

Power Supply: 24" GRIDDLE

Verify that the proper power supply (208/240) is available before plugging the unit in and turning the unit on.

Power Supply: 36" GRIDDLE/48" GRIDDLE

**GRIDDLE MUST BE WIRED BY A QUALIFIED TECHNICIAN**

For Griddles with plugs and leads set, simply provide a suitable power point and connect.

### **Feet**

Install feet by screwing each foot into the threaded openings on the bottom of the griddle. Failure to use feet will void warranty and could cause unsafe conditions.

### **Leveling**

Level unit by adjusting the four feet and tighten securely. The adjustable feet have an adjustment of one inch for line-up with other Commercial Pro countertop lines. Check the feet every 60 days to ensure they are tight.

## **COMMISSIONING**

Commissioning of your new griddle is critical to safety, efficiency and the longevity of your product. Commissioning is the thorough and methodical testing of the equipment, sub systems, and systems to ensure that the final product functions properly and safely in its application. By identifying any potential problems (i.e.: Equipment location, ventilation, local fire/electrical codes, installation, operator training and certification), prior to equipment being placed into service, costly outages and potential damages may be avoided. **SAFETY FIRST.**

## **OPERATING INSTRUCTIONS**

Before operating griddle, it should be checked to see that it is sitting level. Adjust the feet to level the griddle. Adjust the feet to level the griddle. Be sure the waste tray has been assembled correctly. Please see diagram below

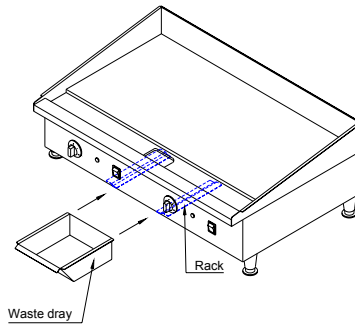

Season the surface:

1. Clean the griddle surface thoroughly. After the griddle has been thoroughly cleaned, it should be seasoned to prevent food from sticking. Before using and after each thorough scouring, season the griddle by heating the surface in the following manner
2. Switch the on/off switch on and adjust the temperature control dials to 350F
3. Using a clean cloth, not a spatula, spread a thin film of cooking oil or fat over the griddle cooking surface. This film should remain on the hot griddle for 30 minutes.
4. Remove the excess fat and wipe clean. (CAUTION - the griddle surface will be HOT)
5. Apply another film of cooking oil over the hot cooking surface for another 30 minutes and again remove the excess fat and wipe clean. The griddle surface will be ready to use.

EVEN WITH CAREFUL SEASONING, FOOD MAY STICK TO THE GRIDDLE COOKING SURFACE UNTIL THE GRIDDLE PLATE IS "BROKEN IN".

- **Temperature Control**  
The temperature is thermostatically controlled. Be sure the On/Off switch is switched on and adjust the thermostats dial to the desired setting. The set point of each thermostat is marked on the facial panel with a – in the 9 o'clock position. Your griddle is equipped with one thermostat per various cooking service interval. For the 24" griddle - every 12", for the 36" griddle - every 18", for the 48" griddle - every 16".
- **Cooking**  
Switch the on/off switch to on and adjust the thermostat dial knob at the desired temperature. After a short pre-heating period, the thermostat will automatically maintain the selected temperature. When the set temperature is reached, the signal light will go off.

## **CLEANING & MAINTENANCE**

It takes very little time and effort to keep the griddle attractive and performing at top efficiency. If grease is permitted to accumulate, it will form a gummy cake and then carbonize into a hard substance that is extremely difficult to remove. To prevent this condition please follow the cleaning steps below:

### **SCRAPING**

After each use, scrape the griddle with a scraper or flexible spatula to remove excess fat and food. A grease drawer is provided for the scrapings. If there is an accumulation of burned fat and food, the griddle should be thoroughly scoured and re-seasoned. Use pumice or griddle stone, while the griddle is warm, to remove excess fat and food. Do not use steel wool because of the danger of steel slivers getting into the food.

### **Body**

Daily, use a clean cloth and a non-abrasive cleaner to clean the stainless steel body of the griddle. Wipe the polished front with a soft cloth.

### **Grease Drawer**

At least once a day, remove the grease drawer and wash. If the grease drawer is permitted to fill too high, the excess grease will run out of the overflow hole at the front of the drawer. The drawer is removed by pulling forward.

USE CAUTION WHEN FILLED WITH HOT GREASE!

### **Controls**

Unit should be turned off when not in use. It is recommended that the unit be disconnected from the power supply by shutting off power disconnect switch.

## **TROUBLE SHOOTING**

<b>Issue</b>	<b>Fault</b>	<b>Action</b>
Griddle Not Working	<ul style="list-style-type: none"> <li>▪ Power supply</li> </ul>	<ul style="list-style-type: none"> <li>▪ Check power source</li> </ul>
	<ul style="list-style-type: none"> <li>▪ Power switch has not been turned on</li> </ul>	<ul style="list-style-type: none"> <li>▪ Check the unit is correctly plugged in and turned on</li> </ul>
	<ul style="list-style-type: none"> <li>▪ Plug/Cord Set/ or External Wiring is damaged.</li> </ul>	<ul style="list-style-type: none"> <li>▪ Call for service.</li> </ul>
	<ul style="list-style-type: none"> <li>▪ Internal wiring fault</li> </ul>	<ul style="list-style-type: none"> <li>▪ Call for service.</li> </ul>
The unit is heating but the indicator light is not on	<ul style="list-style-type: none"> <li>▪ The indicator bulb has blown</li> </ul>	<ul style="list-style-type: none"> <li>▪ Replace the indicator light: call for service.</li> </ul>
Indicator light is on but the unit is not heating	<ul style="list-style-type: none"> <li>▪ Faulty element(s)</li> </ul>	<ul style="list-style-type: none"> <li>▪ Call service agent or qualified technician</li> </ul>
	<ul style="list-style-type: none"> <li>▪ Operation of thermostat</li> <li>▪ All thermostats are not turned on</li> </ul>	<ul style="list-style-type: none"> <li>▪ Ensure that the thermostat is set correctly, also ensure the dial is not spinning on the thermostat and giving the wrong reading</li> </ul>
	<ul style="list-style-type: none"> <li>▪ Faulty thermostat</li> </ul>	<ul style="list-style-type: none"> <li>▪ Call service agent or qualified technician</li> </ul>
Slow heat up of the cooking surfaces	<ul style="list-style-type: none"> <li>▪ Carbon build up</li> </ul>	<ul style="list-style-type: none"> <li>▪ Ensure that the plates are kept clean and free of carbon build up</li> </ul>
	<ul style="list-style-type: none"> <li>▪ Thermostat setting</li> </ul>	<ul style="list-style-type: none"> <li>▪ Ensure that the thermostat is set correctly, also ensure the dial is not spinning on the thermostat and giving the wrong reading</li> </ul>
	<ul style="list-style-type: none"> <li>▪ Faulty element(s)</li> </ul>	<ul style="list-style-type: none"> <li>▪ Call service agent or qualified technician</li> </ul>
Food Sticking	<ul style="list-style-type: none"> <li>▪ Carbon build up</li> <li>▪ Not Seasoned</li> </ul>	<ul style="list-style-type: none"> <li>▪ Ensure that the plates are kept clean and free of carbon build up</li> <li>▪ Season grill, see cleaning and maintenance.</li> </ul>

**Please work through the above steps before calling a service agent if problems occur.  
Toll Free service calls: 1-800-439-7977**

**EXPLOSION DRAWING**  
**Modell CPG24, CPG36**

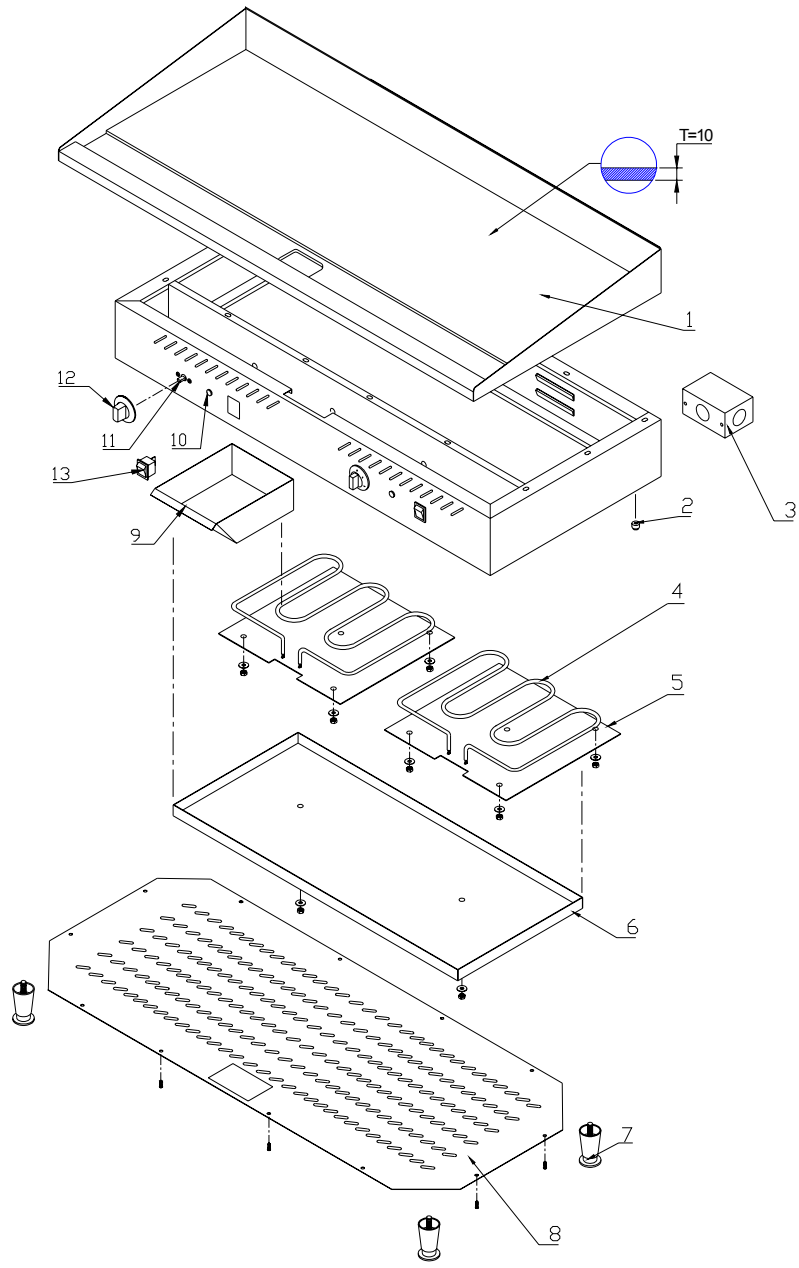

**EXPLOSION DRAWING**  
**Model CPG48**

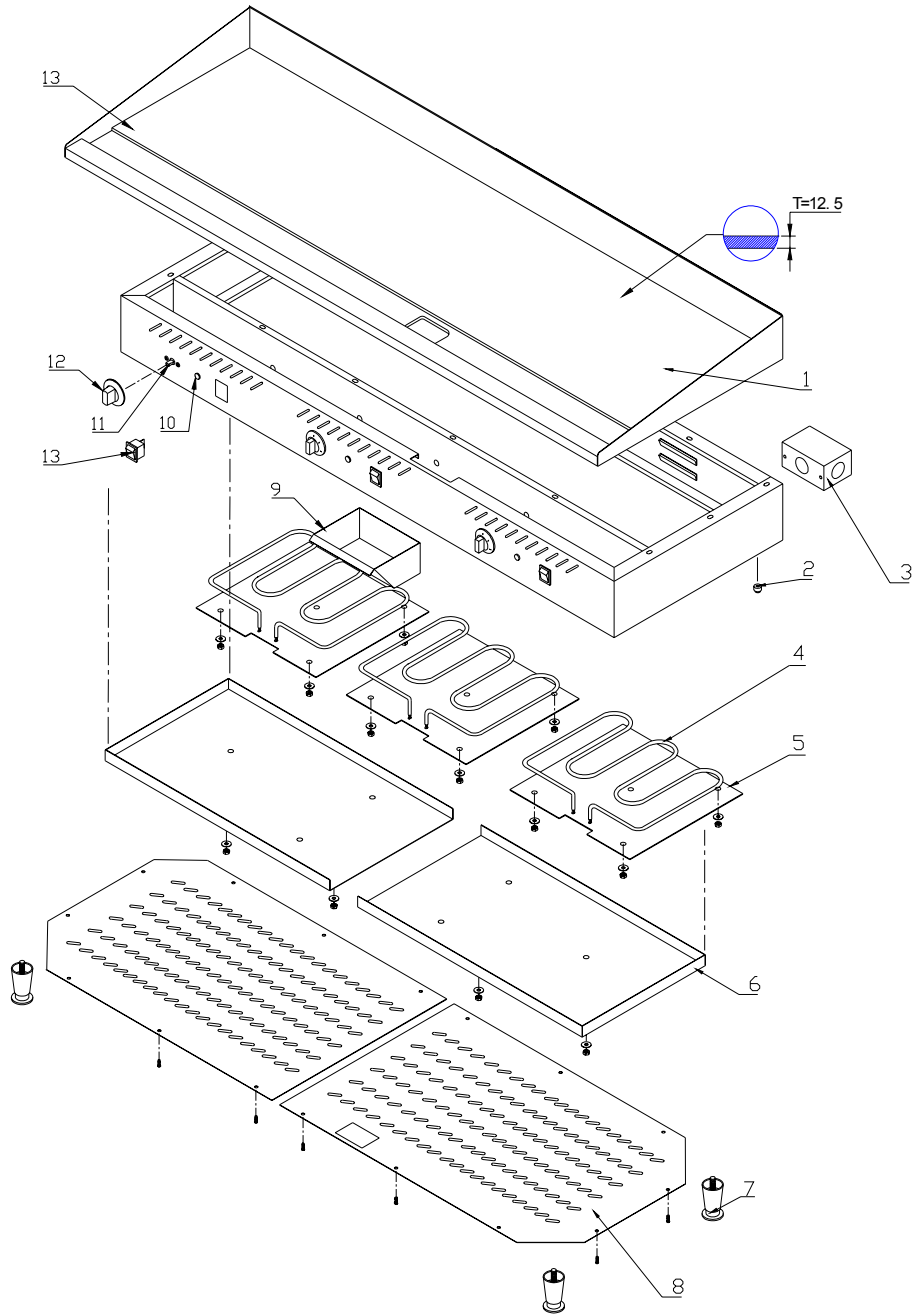

# CIRCUIT DIAGRAMS

## Model CPG24, CPG36

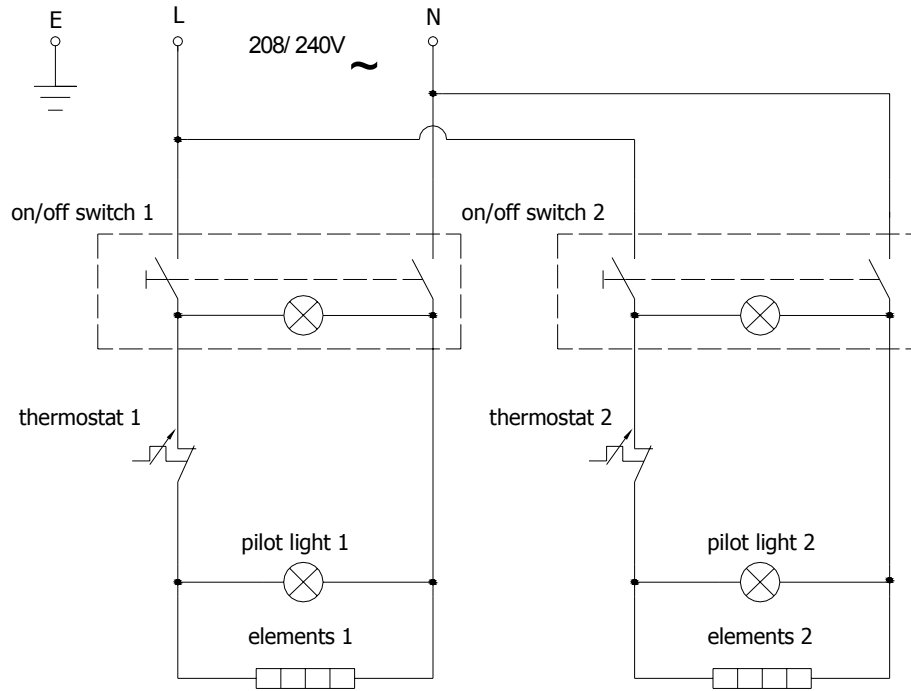

## Model CPG48

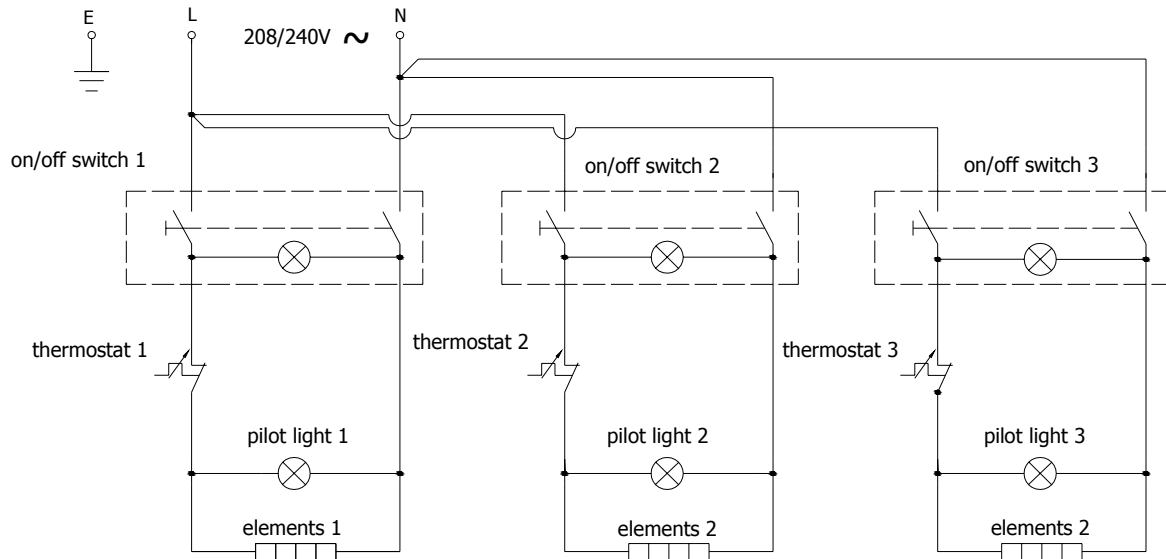

**PARTS LISTING**

No.	Description	QTY	Part NO.
1	GRIDDLE PLATE	1	P03020010-SG24,CPG24 P03020009-SG36,CPG36 P03020011-SG48,CPG48
2	CERAMIC TUBE	4	P02160001
3	CONNECTION BOX	1	L04890B13
4	HEATING ELEMENT	2	P01020064-SG24,CPG24 P01020065-SG36,CPG36 P01020066-SG48,CPG48
5	ELEMENT FIXING PLATE	2	L04890B01-SG24,CPG24 L04910B01-SG36,CPG36 L04920B01-SG48,CPG48
6	CLAMP	1	L04890B02-SG24,CPG24 L04910B02-SG36,CPG36 L04920B02-SG48,CPG48
7	FEET	4	P02130006
8	BASE PLATE	1	L04890B03-SG24,CPG24 L04910B03-SG36,CPG36 L04920B03-SG48,CPG48
9	DRIP TRAY	1	L04890B11
10	INDICATOR LIGHT	2	P01130106-SG(CPG)24,36 SG48,CPG48
11	THERMOSTAT	2	P01045300-SG(CPG)24,36 SG48,CPG48
12	DIAL	2	P02010575-SG(CPG)24,36 SG48,CPG48
13	ON/OFF SWITCH	2	P01160307-SG(CPG)24,36 SG48,CPG



Tentative Interim Amendment

## NFPA 96

# Standard for Ventilation Control and Fire Protection of Commercial Cooking Operations

2004 Edition

Reference: 2.1.2.3, 4.3.1  
TIA 04-2 (NFPA 96)  
SC# 05-1-14/Log 801

Pursuant to Section 5 of the NFPA Regulations Governing Committee Projects, the National Fire Protection Association has issued the following Tentative Interim Amendment to NFPA 96, *Standard for Ventilation Control and Fire Protection of Commercial Cooking Operations*, 2004 edition. The TIA was processed by the Venting Systems for Cooking Appliances Committee, and was issued by the Standards Council on January 14, 2005, with an effective date of February 3, 2005.

A Tentative Interim Amendment is tentative because it has not been processed through the entire standards-making procedures. It is interim because it is effective only between editions of the standard. A TIA automatically becomes a proposal of the proponent for the next edition of the standard; as such, it then is subject to all of the procedures of the standards-making process.

1. Add new section 2.3.1 and renumber 2.3.1 and 2.3.2 as 2.3.2 and 2.3.3.

**2.3.1** ASTM Publications.

ASTM International, 100 Barr Harbor Drive, West Conshohocken, PA 19428-2959

ASTM E2336-04 Standard Test Methods for Fire Resistive Grease Duct Enclosure Systems.

2. Revise section 4.3.1 to read:

4.3.1 Field-applied grease duct enclosures and factory-built grease duct enclosures shall be listed in accordance with UL 2221, *Standard for Tests of Fire Resistive Grease Duct Enclosure Assemblies*, or ASTM E2336 Standard Test Methods for Fire Resistive Grease Duct Enclosure Systems, and installed in accordance with the manufacturer's instructions and the listing requirements.

Copyright © 2005 All Rights Reserved  
NATIONAL FIRE PROTECTION ASSOCIATION

## Limited Warranty

Your new CPI product is warranted to the original purchaser for a period of one year from the date of purchase.

This limited warranty is against defects from original factory imperfections in material and/or workmanship and includes labor for replacement of defective parts, provided repairs are performed by an authorized service agency. Our obligation under this warranty is limited to repairing or replacing any part or parts thereof. The CUSTOMER must inform the Service Agency of warranty coverage and provide a copy of the dated sales or delivery receipt BEFORE WARRANTY REPAIRS BEGIN. Replacement parts and accessories are warranted for ninety (90) days from the date of purchase when purchased separately and will be verified to date sales receipt or packing slip from the item. All parts or accessories replaced under warranty must be returned to the Service Agency.

This warranty applies only to equipment under normal use and service in the USA and Canada. It does not apply to any item which had been repaired or altered in any way so as, in the judgment of CPI to affect its reliability.

The following are not covered under warranty; CPI will not accept liability for the following:

- The instructions in this manual have not been followed correctly.
- Non-authorized personnel have tampered with the Equipment.
- Non-original spare parts are used.
- The Equipment has not been handled and cleaned correctly.
- There is any use damage to the unit.
- Damage caused by abuse, misuse, dropping or other similar incidental damaged caused by or as a result of customer failure to follow assembly, operating, cleaning, user maintenance or storage instructions.
- Labor to replace inoperative parts such as bulbs, plugs or racks due to normal use or abuse.
- Materials or labor to repair scratched, stained, chipped, pitted, dented or discolored surfaces, attachments or accessories.
- Transportation charges to or from a service agency for repair of your machine. If you should have questions relating to this issue, please call CPI at 1-800-328-9400.
- Labor charges to install or test attachments or accessories, which are replaced for any reason.
- Shipping Damages. Visible and hidden damages are the responsibility of the freight carrier. The consignee must file the claim promptly against the carrier. KEEP ALL ORIGINAL CONTAINERS AND PACKING MATERIALS FOR CARRIER INSPECTION.
- Products placed or stored in the equipment are not subject to this warranty and no responsibility is assumed thereof.

THIS WARRANTY IS GIVEN EXPRESSLY AND IN LIEU OF ALL OTHER WARRANTIES, EXPRESSED OR IMPLIED FOR MERCHANTABILITY AND FOR FITNESS TOWARD A PARTICULAR PURPOSE OR CONSTITUTES THE ONLY WARRANTY MADE BY CPI. IT NEITHER ASSUMES, NOR AUTHORIZES ANY PERSON TO ASSUME FOR US, ANY OTHER LIABILITY IN CONNECTION WITH THE SALE OF SUBJECT EQUIPMENT

Please call CPI for service information at 1-800-439-7977

### TERMS AND CONDITIONS OF SALE

Acceptance: Orders are subject to acceptance by Home Office.

Price Changes: All prices are subject to change without notice.

Damaged Merchandise: Inspect merchandise immediately on receipt and notify carrier if shipment is damaged. All Claims must be filed with carrier.

Cancellation: Cancelled special or custom orders within one week of scheduled shipment are subject to a cancellation charge of 10%-25%, depending on the specifics of the order.

### Return Policy

CPI will consider the return of equipment under the following terms and conditions:

Must be pre-approved by customer service in writing

RMA number must be assigned, then noted on the shipping label and bill of lading. This is extremely important.

Must be new and unused, in the original packaging, freight prepaid

Must be returned within 45 days of the original shipment

Must be of current design.

If a return is approved, the following charges will apply:

A restocking fee of 25% on all products

Applicable freight charges

Freight damages (if any)

Refurbishing to new for resale, including testing and re-packaging.

### QUOTATION POLICY

Quotations are subject to acceptance within 30 days and for shipment within 3 months for the date of the quotation. For extended price protection beyond 3 months, please contact the Home Office. Optional accessories on equipment shown in photographs are not included in the list price.

CPI pursues a continuous research program of design and product improvement. Therefore, modification in materials and specifications may be made at any time without notice.



**Commercial Pro International**

Toll free: 800-439-7977

[www.commercial-pro.com](http://www.commercial-pro.com)